

**2019 NDIA GROUND VEHICLE SYSTEMS ENGINEERING AND TECHNOLOGY
SYMPOSIUM
VEHICLE ELECTRONICS & ARCHITECTURE (VEA) & GROUND SYSTEMS CYBER ENGINEERING
(GSCE) TECHNICAL SESSION
AUGUST 13-15, 2019 - NOVI, MICHIGAN**

**MODULAR OPEN RF ARCHITECTURE (MORA):
STANDARDIZING THE RF CHAIN**

Jason Broczkowski¹, Derek Bailey², Troy Ryder³, Jason Dirner³

¹ASRC Federal, Aberdeen Proving Ground, MD

²Aspen Consulting Group, Aberdeen Proving Ground, MD

³C5ISR Center, Aberdeen Proving Ground, MD

ABSTRACT

The Modular Open RF Architecture's (MORA) core objective is to logically decompose radio frequency (RF) systems for efficiency, flexibility, reusability, and scalability while enabling management, health monitoring, and sharing of raw and/or processed data. MORA extends the Army's Vehicular Integration for C4ISR/EW Interoperability (VICTORY) architecture. MORA was introduced to the GVSETS community in 2015 at version 1.0 of the specification, and has matured with the help of community, industry, and academia partners to its current version 2.3. This paper discusses the current state of the MORA specification and how it has evolved beyond its initial topology to encompass the entirety of the RF chain in an open and modular fashion. In addition, this paper will describe the purpose of MORA, the objectives of its development, its foundation, and the basic concepts and core features.

Citation: J. Broczkowski, D. Bailey, T. Ryder, J. Dirner, "Modular Open RF Architecture (MORA): Standardizing the RF Chain", In *Proceedings of the Ground Vehicle Systems Engineering and Technology Symposium (GVSETS)*, NDIA, Novi, MI, Aug. 13-15, 2019.

1. INTRODUCTION

Radio Frequency (RF) systems are typically implemented with a narrow scope, tailored to a particular function with either an individual or suite of specific hardware and software components to achieve that mission. While specialized equipment is invaluable for bringing capabilities to the warfighter, this practice of bolt-on, stove-piped

products introduces a host of issues to the government and the warfighter over time. The following caveats apply to all platform systems, not only those in the area of RF: cost of redundant hardware components already on the platform, increased Size, Weight, and Power (SWaP) infringing on crew stations in vehicles, maintenance and procurement of replacements, longer timelines and reduced flexibility for capability insertions, etc. While there are many concurrent efforts to address these issues as well as

a thrust to adopt open standards [1] within the Department of Defense, the MORA Specification [2] has been created and iterated upon to address the RF landscape specifically.

Previous efforts at open architectures within the RF realm focused primarily on the development and maturation of Software Defined Radios (SDR) meant to advance the portability of digital processing and waveform applications, independent of RF chain stages. However, RF chain control messaging (e.g. frequency tuning, gain setting, filter selection, transmit/receive functions) has remained vendor-specific and in some cases, model and/or system specific within the same vendors, making the need for “drivers” a way of life within signal data processors. To truly allow for dynamic and multi-mission RF chain construction, capability profiles, resource management/control, and data and context messaging needs to be standardized.

2. OBJECTIVES

RF products spanning multiple functions have become increasingly critical to the warfighter. Military use of the electromagnetic spectrum now includes communications, electronic warfare, intelligence, and mission command systems. Due to the manner in which military capabilities are most often designed, current RF system implementations are typically single-mission focused with closed or proprietary interfaces between stove-piped resources.

The objective of MORA is to provide standardized access and control of the RF chain. This standardization provides several benefits, including the enabling of resource sharing, which provides efficiencies in SWaP. Additionally, it enables multi-mission operations and moves the DoD towards its objective of multi-nodal operations. The standardization helps to eliminate the burden of driver development and the use of discrete signal lines through the use of standardized digital messaging transported on one of two networks. Through breaking the traditional

stovepipes, MORA supports development of interoperable and portable RF systems within the government and industry while still providing space for proprietary and best-in-class solutions for the DoD.

3. FOUNDATION

The Army’s Vehicular Integration for C4ISR/EW Interoperability (VICTORY) [3] defined an Ethernet-based network architecture for integrating electronic systems within military ground vehicles, as well as interface specifications for sharing sensor and data products, managing configuration, modes, and health of the infrastructure and applications, transporting data with quality of service, and implementing necessary information assurance controls to protect the system and its data. VICTORY supports the non-time critical messaging and management of RF systems, which includes setup, tasking, and monitoring of RF processing chains, and transport of lower-volume processed data messages. However, extensions to VICTORY are required to support the transport of large-volume signal data streams and to standardize the access and low latency control of the RF chain.

MORA extends the scope of VICTORY by adding a low latency transport mechanism, data streaming interfaces, new message types, management operations, and functional concepts that are specific to RF applications.

MORA decomposes RF components into logical groupings of interfaces enabling management, health monitoring, and dissemination of raw and/or processed data across two physical buses. It uses the VICTORY Data Bus (VDB) for access control, transport for publish/subscribe data streams, and device-level web-services for management. Additionally, it recommends leveraging VICTORY’s Position, Navigation, and Time (PNT) services.

To achieve its goal, MORA also utilizes a specific implementation of standards from the VMEbus International Trade Association (VITA) for control and dissemination of data and context on the

MORA Low Latency Bus (ML2B). VITA 49.0 established standards for receive-only data and context while VITA 49.2 added transmit functionality and control messaging. MORA leverages a subset of VITA 49.2 in a locked-down manner to support true interoperability. The MORA development group within the C5ISR Center worked closely with the VITA 49 Working Group to provide input and implement necessary

processing resources in support of receive and/or transmit operations. There are three MORA Device Types - Software Defined Radio (SDR), RF Conditioning and Distribution (RCD), and Radiohead (RHD). The MORA specification is bounded to encompass two resource layers, known as MORA Signal Resources and MORA Processing Resources, as shown in *Figure 1* below. These signal resources encompass the RF chain for

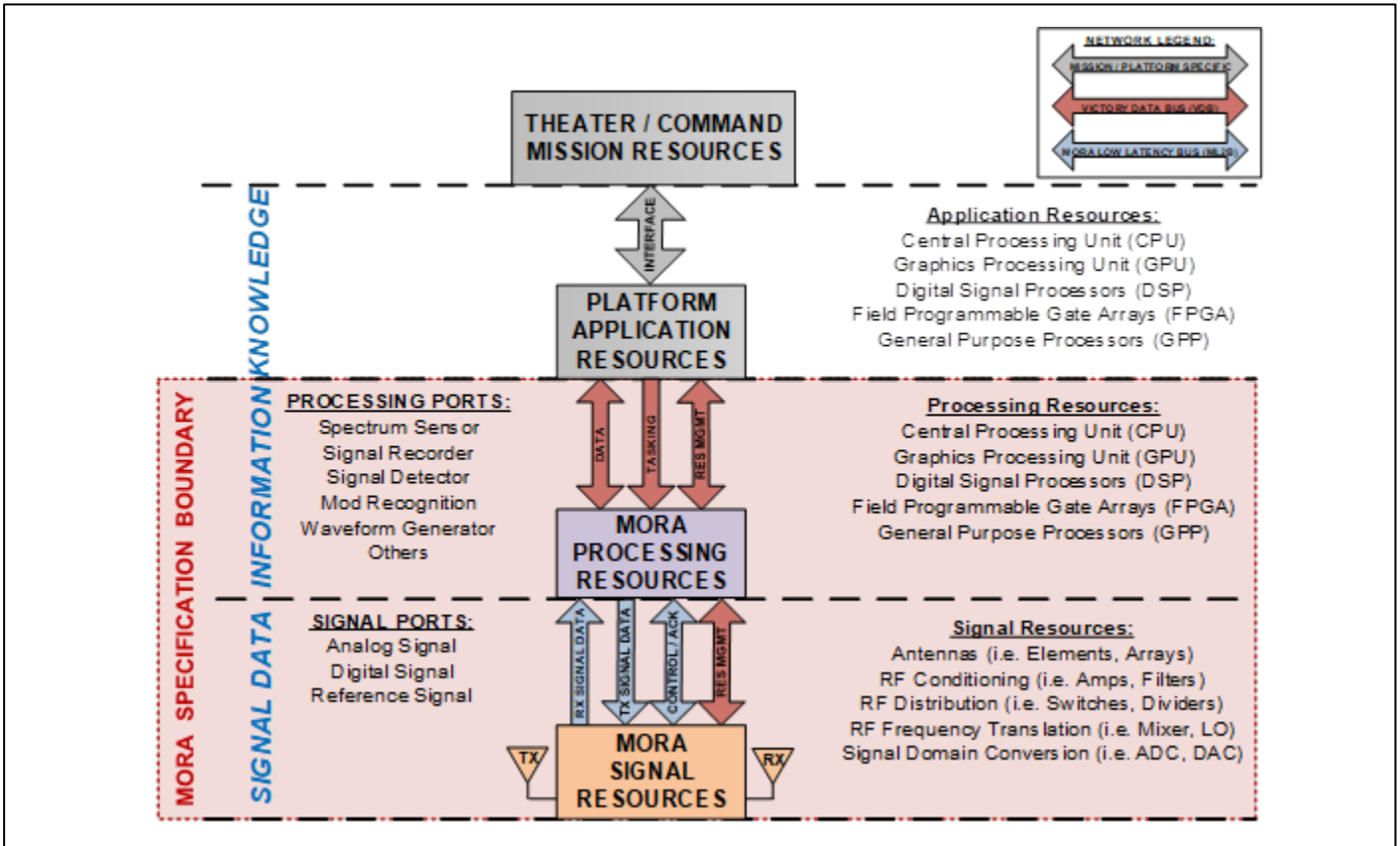

Figure 1: MORA Top-Down Perspective

changes in the 49.2 revision of the specification [4].

MORA’s dual bus architecture supports the varied latency and throughput constraints as well as providing a natural boundary for potentially sensitive data.

4. BASIC CONCEPTS

A MORA Device is an entity within a MORA system that contains signal resources and/or

both receive and transmit functions, including the antenna and extending to the analog-to-digital converter (ADC) / digital-to-analog converter (DAC). This signal resource RF chain is further decomposed into five Signal Resource Types, including Antenna (ANT), RF Conditioning (RFC), RF Distribution (RFD), RF Frequency Translation (RFT), and Signal Domain Conversion (SDC).

The MORA Specification boundary also extends to those interfaces required to speak to standardized MORA Processing Resources. These Processing Resources are meant to be RF processes which will likely be reusable and/or of use to a third-party client. Processing resources are component types that exist to convert raw data into useful information, convert information into raw data, or further process information and share it on the VDB in digestible formats for client consumption. This alleviates the barrier of entry, simplifying the

bandwidth, and threshold. LOB information is sent to the client through its data interface on the VDB. This data interface includes task specific responses that include azimuth bearing and confidence, elevation bearing and confidence (for 3D types), received signal strength, and position (starting point of the LOB vector). A DFE leverages MORA Signal Resources to obtain data streams for processing and subsequently provides situational awareness to any interested client through a set of standardized messages, consequently either adding

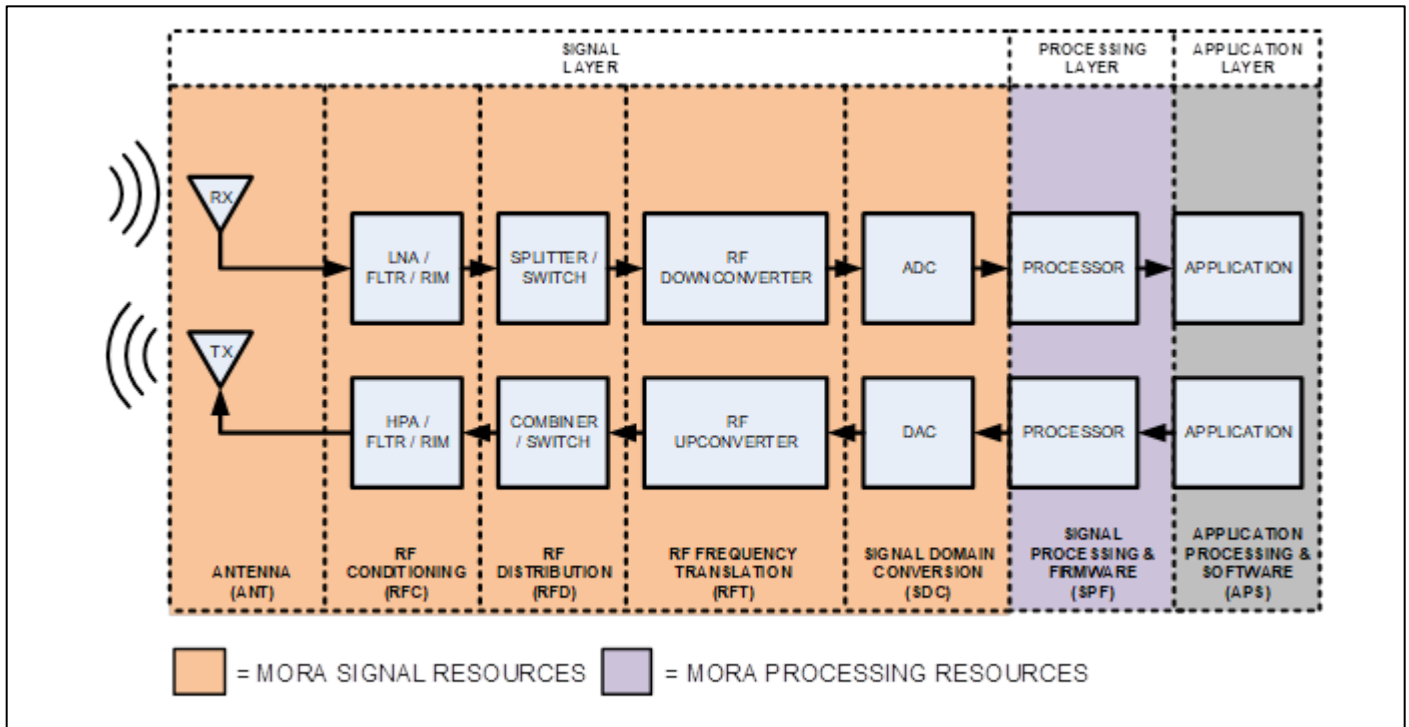

Figure 2: MORA Functional Perspective

adoption by new and existing technologies to ingest EM/RF information.

One such example, developed as part of a reference design, is a Direction Finding Engine (DFE). A DFE produces lines-of-bearing (LOB) information for signals of interest, derived from multi-channel digital receive signal data streams. Management interfaces includes task-specific settings such as the desired mode (set-on or scan), LOB type (2D or 3D), timing, duration, number of repetitions, repetition interval, frequency,

capability to networked systems or reducing redundant processing.

As shown in Figure 2, Signal Resource Types provide interfaces for basic components of the RF chain, while Processing Resources will either ingest or provide digital data and provide defined interfaces for tasking and response messages from applications.

5. CORE FEATURES

One of the primary benefits of MORA is in the flexibility in system design implementation. MORA is unique from many other RF architectures in that it does not dictate where RF resources are implemented. Instead, it simply defines how these resources announce their existence, their adjustable parameters, and their place in the larger system. This allows for a bottom-up discovery of resources and, through the defined interfaces which users and other MORA resources utilize, enables dynamic construction of an RF chain with mission-agnostic standard messages.

MORA also supports partial implementations for capability and technology insertions into existing systems by offering standardized access to newly introduced MORA Signal and Processing Resources from other pre-existing, un-exposed resources already in place. MORA Signal Resources can also feed into newly introduced MORA Processing Resources, which in turn provide new capabilities to pre-existing application resources.

Another core feature of MORA is its use of VITA Radio Transport (VRT) within its MORA Data Message (MDM) Type 1 for control and context of analog and digital signal streams. MDM Type 1 messages provide command, data, and context of temporal and spectral data streams to/from radios and users to promote interoperability between RF systems. MDM VRT messages are defined within the MORA Specification and the *ANSI/VITA-49.2-2017 VITA Radio Transport (VRT) Standard* [4]. The MORA Specification takes precedence over the VITA 49.2 Standard by limiting and providing further definition to ensure interoperability in MORA systems.

6. MORA SPECIFICATION MATURATION

MORA was introduced to the GVSETS community in 2015 at version 1.0 of the specification. Many aspects of the early versions of MORA have been enhanced over time as reference

designs provided insight in how to improve the modularity and broaden the use cases supported.

The MORA specification development team continually iterates over the specifications to address self-identified findings or those brought forth by its community. MORA has continued to evolve beyond its initial topology to encompass the entirety of the RF chain in an open and modular fashion. It has matured with the help of community, industry, and academia partners. Findings and feedback from reference builds, demonstrations, requests for information (RFI), and continued experimental developments have been incorporated into subsequent specification releases of MORA. Currently, the MORA Specification is at version 2.3.

7. MORA ARCHITECTURE DETAILS

7.1. MORA Terms

The “Basic Concepts” section above covers the overarching architecture and is not repeated here. MORA defines a number of terms, many of which will be briefly described here for context.

MORA Device: An entity within a MORA system that contains signal resources and/or processing resources in support of receive and/or transmit operations. MORA Device types include: Radiohead, RF Conditioning and Distribution, and Software Defined Radio. MORA Device subtypes include Receive Only (RXO), Transmit Only (TXO, Transmit or Receive (TOR), and Transmit and Receive (TAR).

MORA Signal Resource: A resource within a MORA Device that captures, radiates, conditions, distributes, translates, and/or converts RF signals in support of receive and/or transmit operations in a MORA system. Signal Resource types include: Antenna (ANT), RF Conditioning (RFC), RF Distribution (RFD), RF Frequency Translation (RFT), and Signal Domain Conversion (SDC).

MORA Signal Port: A logical partition of signal resources with an external access point on a MORA

Device in support of receive and/or transmit operations in an RF system. A MORA Signal Port consists of analog (radio frequency, intermediate frequency, or baseband) or digital (real or complex IQ in time or frequency domains) signals transported between devices in coaxial, copper wire, or fiber optic interconnect cables. MORA Signal Port classes include the Analog Signal, Digital Signal, and Reference Signal classes.

MORA Processing Resource: A resource within a MORA Device that processes signal data into information, processes information into signal data, or further processes information in support of receive and/or transmit operations in a MORA system. A processing resource can contain either one signal port and one processing port or two processing ports.

MORA Processing Ports: A logical partition of processing resources with an external access point on a MORA Device in support of receive and/or transmit operations in an RF system. Processing ports include management and data interfaces on the VICTORY Data Bus (VDB) and may also interface with signal resources through signal ports on the MORA Low Latency Bus (ML2B). The information consists of digital formats transported between devices in copper wire or fiber optic interconnect cables.

7.2. MORA Component Types

The four (4) MORA component types are (1) Low Latency Switch, (2) MORA Device, (3) MORA Signal Resource Manager, and (4) MORA Signal Port Manager. The Low Latency Switch defines requirements for switch(s) comprising the ML2B.

The MORA Device component type is the logical representative of the hardware device as a whole. The MORA Device specific management interface supports file operations, configuration, device level commanding, and responding to queries for device status and description. The waveform management interface (if supported, such as an SDR) also exists under MORA Device for reporting and managing

available waveforms. The MORA Device interfaces with both the VDB and the Signal Port Manager for device level commanding, nominally via an intra-device medium.

The MORA Signal Resource Manager component type is the logical representative of all RF Signal resources that are a part of the device. Its specific management interface includes support for fetching signal port information and descriptions (RFC, RFT, or SDC and sub ports) in fine detail, management and reporting of reservations per signal port, reporting signal port default performance data, retrieving internal reference connections as well as static internal and external connections, and fetching antenna array and manifold band information. Additionally, the RF Distribution management interface (if supported, such as an RCD) exists for fetching switch group information, and management and reporting of reservations per switch group. The Signal Resource Manager interfaces with the VDB and the Signal Port Manager, nominally via an intra-device medium.

The MORA Signal Port Manager component type has direct control of all of the signal ports and RF components, executing configuration, tuning, and commands received from MORA Device, MORA Signal Resource, or MORA Signal Port Manager clients. It uses implementation specific protocols to achieve this, allowing for MORA clients to communicate in standardized MORA Data Message (MDM) syntax, described later. *Figure 3* shows these component types in the high-level, dual-bus MORA Architecture with the three MORA Device Types. *Figure 4*, below, shows the high-level communication amongst the component types, and clients.

7.3. MORA Data Messages

Communication on the ML2B, or intra-device, is accomplished with MDMs. MORA adopts and/or adapts from VITA 49.2 specifications, which come from a standards body that has already defined

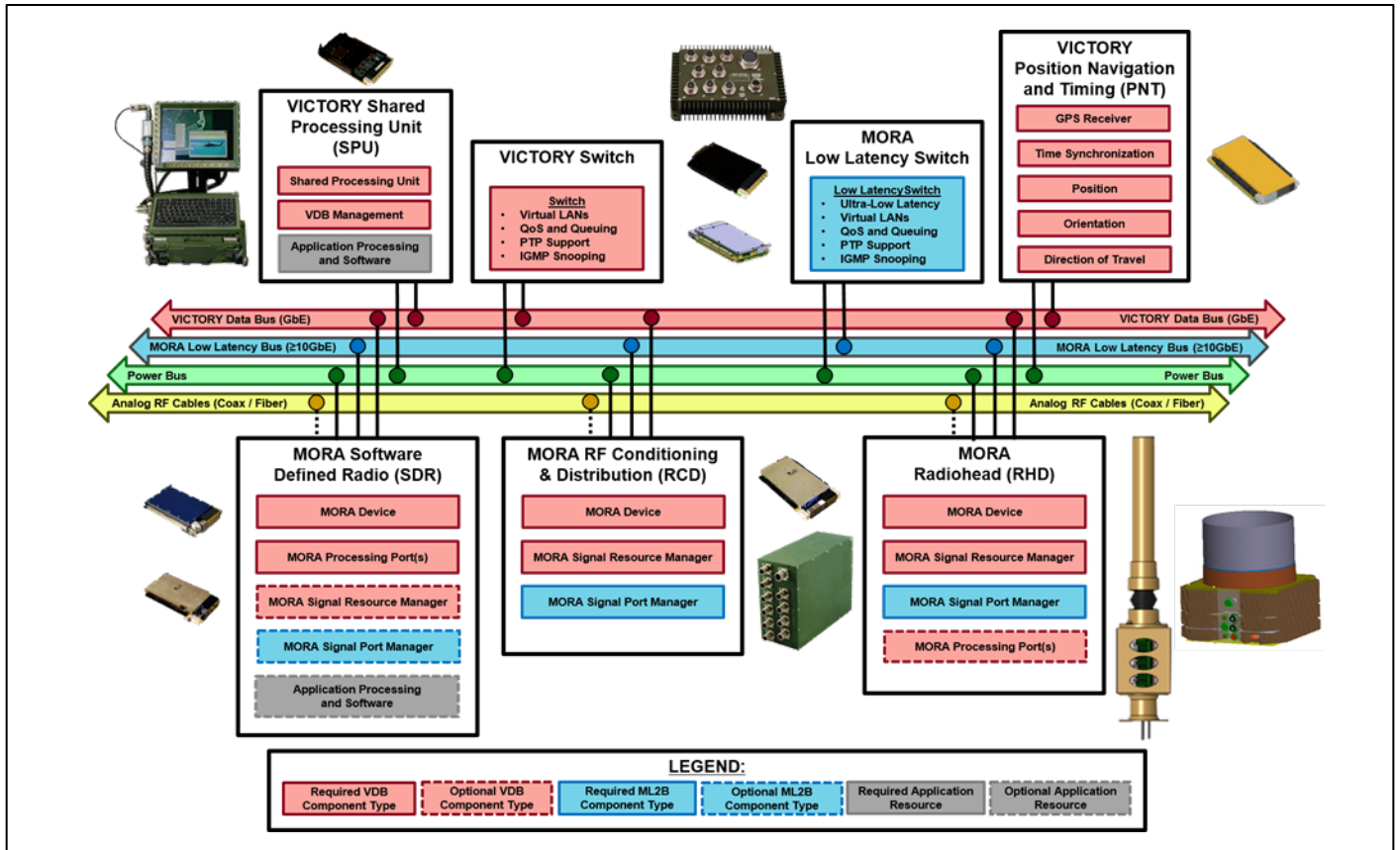

Figure 3: MORA Component Types & Architecture

protocol-agnostic messages in the extremely complex RF domain. There are currently seven (7) types of MDMs.

MDM VITA Radio Transport (VRT) (Type 1): MDM VRT (Type 1) messages provide command, data, and context of temporal and spectral data streams to/from radios and users to promote interoperability between RF systems. VRT Type 1 messages have three (3) variants: VRT Command, VRT Context, and VRT Signal Data.

MDM Acknowledge Message (Type 2): The MDM Acknowledge Message provides a positive acknowledgement to the sender of certain MDMs that a specific message was received by the recipient. In addition to delivery confirmation functionality, the MDM Type 2 also provides a means by which the recipient may further delineate success or failure in executing the delivered message.

MDM Time of Day (ToD) Message (Type 3): The MDM Time of Day Message is used to achieve time synchronization between the VDB, which nominally has Network Time Protocol (NTP) and/or Precision Time Protocol (PTP) provided by a VICTORY Time Synchronization Service, and the Signal Port Manager on the ML2B.

MDM Signal Port User ID Message (Type 4): The MDM Signal Port User ID Message is intended to provide a means to communicate that a reservation or release of a signal resource has occurred.

MDM Health Message (Type 5): The MDM Health Message is used to convey health and status about the MORA Signal Port Manager, and its constituent parts, to the MORA Device and MORA Signal Resource component types so that the information can be converted to VICTORY's

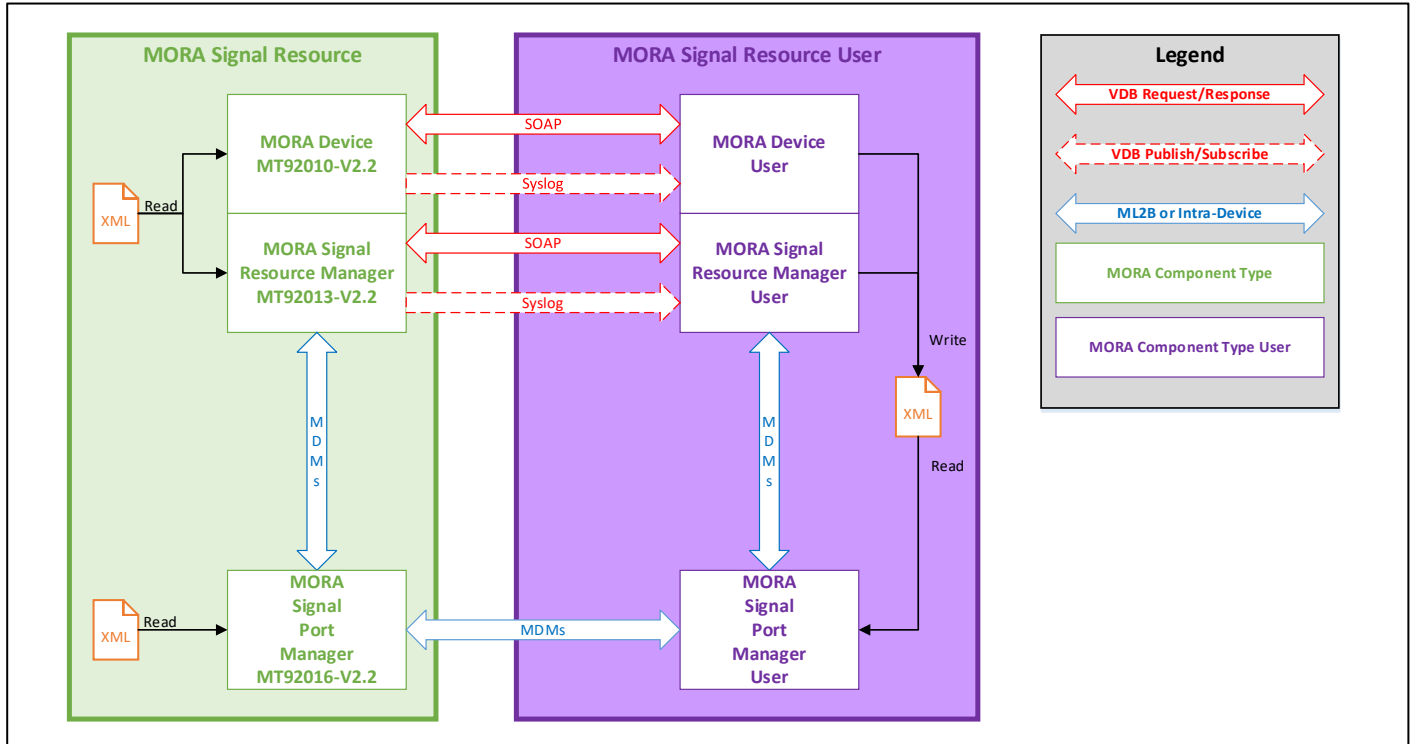

Figure 4: MORA Component Type Interaction

Syslog-Based Health Publishing Interface and format.

MDM Command Message (Type 6): The MDM Command Message is utilized for course device-level communication. For instance, instructing the unit to go into a certain mode like operate, standby, or transmit inhibit, or actions like shutdown, restart, or zeroize.

MDM Switch Port User ID Message (Type 7): The MDM Switch Group User ID Message is intended to provide a means to communicate that a reservation or release of switch group has occurred.

8. CONCLUSION

After various R&D implementations from community, industry, and academia partners, lessons learned helped to refine the MORA specification. MORA v2.3 brings opens standards and thoughtful decomposition to the RF chain, radios, and applications for singular or multi-mission capabilities. Programs can reduce initial technical risk, cost, and schedule with MORA

while lowering sustainment costs and reducing time to insert new capabilities in the long term.

9. REFERENCES

- [1] Tri-Service Memorandum, “Modular Open Systems Approaches for our Weapon Systems is a Warfighting Imperative”, 07 Jan 2019.
- [2] CCDC C5ISR Center, “MORA Specification v2.2, 28 Sep 2018”, and “MORA Specification v2.3”, 20 May 2019.
- [3] Vehicular Integration for C4ISR/EW Interoperability (VICTORY) Standard Specifications, Version 1.7, 15 February 2018.
- [4] ANSI/VITA-49.2-2017 VITA Radio Transport (VRT) Standard for Electromagnetic Spectrum: Signals and Applications, Revision 00.55.